



Instructions for use

GB



**Fiamm Motive Power
energy plus / LM200
ATEX**

Instructions for use energy plus / LM200 ATEX

ENGLISH

Motive power batteries EEx certified increased safety "e" Operation and Instruction Manual

Introduction

These FMP ATEX batteries are certified for use in areas with risks of explosion due to gas or dust.

- group I category M2
- group II category 2 and 3 [zone 1, 2 (gas) and 21, 22 (dust)]

They should be in perfect condition and free from any damage. If any damage is noted or accessories missing please contact your supplier within the first 24 hours of receiving this product. EEX traction batteries are designed for use in battery powered applications within hazardous areas : such as electric counter balance, reach and pallet trucks also floor sweepers and other cleaning equipment. The cells and connectors comply with IP (ingress protection) 66, the crates with IP23. The patented ventilation design makes it possible for these traction batteries to fit within existing DIN and British standard crate sizes, offering the same capacity, as specified, by the truck manufacturer.

Conformity

Motive power FMP ATEX batteries conform with the relevant provision of directive 94/9/EC of 23 March 1994. Conformity has been demonstrated with reference to the following documentation :

EC type-examination certificates:

ATEX

- SIRA 01ATEX3016U
- SIRA 01ATEX3019U
- SIRA 01ATEX3022
- SIRA 01ATEX3025

IECEX

- SIRA IECEX 07.0061U
- SIRA IECEX 07.0062U
- SIRA IECEX 07.0065
- SIRA IECEX 07.0066

Description

- Flooded BS cell
- Flooded DIN cell
- Batteries up to 860 Ah capacity
- Batteries above 860 Ah capacity

ATEX certificates apply to the EEC and IECEX certificates apply to the rest of the world except North America (USA and Canada).

Quality Assurance Notification:

Sira 01 ATEX M103 dated 15/06/01

Rating Data

1. Nominal capacity C_5
2. Nominal voltage
3. Nominal discharge current
4. Nominal S.G. of electrolyte*
5. Rated temperature
6. Nominal electrolyte level

*Will be reached within the first 10 cycles

- : See type plate
- : 2.0 V x No of cells
- : $C_5/5h$
- : 1.29 kg/l
- : 30°C
- : up to electrolyte level mark "max."



- Pay attention to the operation instruction and fix them close to the battery.
- Work on batteries to be carried out by skilled personnel only!



- Use protective glasses and clothes when working on batteries. Pay attention to the accident prevention rules as well as EN 50272-3 and EN 50110-1.



- No smoking!
- Do not expose batteries to naked flames, glowing embers or sparks, as it may cause the battery to explode.



- Acid splashes in the eyes or on the skin must be washed with water. In case of accident consult a doctor immediately!
- Clothing contaminated by acid should be washed in water.



- Risk of explosion and fire, avoid short circuits!
- Caution: Metal parts of the battery are always live. Do not place tools or other metal objects on the battery!



- Electrolyte is highly corrosive.



- Batteries and cells are heavy. Ensure secure installation!
- Use only suitable handling equipment e.g. lifting gear in accordance with VDI 3616.



- Dangerous electrical voltage!



- Pay attention to the hazards that can be caused by batteries.

Ignoring the operation instructions, repair with non-original parts or using additives for the electrolyte will render the warranty void.

1. Safety

Always remember that the battery is a source of power, even when fully discharged there remains sufficient energy in the battery to cause serious damage.

Follow these safety codes

- Never charge a EEx battery in the zoned controlled area.
- Never disconnect the battery in a zoned area. Isolate circuits before disconnecting the battery outside a zoned area.

- Never open the battery cover in a zoned area.
- Always use certified DC plugs for connection to the battery.
- Never use the battery if damaged or bare cables are evident.
- Never use the battery if the DC plugs are damaged.
- Never attempt to repair the battery: Call your recommended authorised service centre.
- Close vent plugs lids firmly when topping the batteries electrolyte has been completed.

2. Service

Your local authorised service engineer provides local help and support. This handbook gives guidelines of a general nature; our engineer will help you to interpret your needs in relationship to your particular requirements.

Your authorised engineer can answer the questions that are beyond the scope of this manual and obtain specialist help should it be required. Your battery is an expensive investment and designed for use in a zoned area, it is our aim to help you obtain the best possible results from it. Please do not hesitate to call your local service centre if you have any questions relating to the battery.

3. Handling

Lead acid EEx batteries are very heavy. Always use approved moving equipment when attempting to change batteries. When lifting and handling the EEx batteries use the correct approved lifting equipment and keep the battery in an up right position. Due to the wide variation in types of electric vehicles, designs of battery containers, equipment used and methods of battery changing, it is not possible to give detailed instructions on the procedures to be followed when changing the batteries on an electric vehicle. The manufacturer of the vehicle or the battery changing equipment must supply the correct method and procedure.

4. Taking delivery of your battery

Do not carry out any of the following procedures in a zoned area.

The possibility of the battery being connected in the wrong polarity is prevented by visibly marking the polarities adjacent to the connection plug with an identification colour (Positive Red and Negative Blue). The possibility of the insulation on the overall battery voltage leads being cut to expose the conductor is prevented by sleeving the insulation with cable retention (i.e. spiral wrap).

Please ensure that the battery containers are always upright so that the electrolyte is not spilled. Remove all packing material and carefully examine the containers, etc. to ensure that there is no physical damage.

If the battery is not used at receipt, please refer to (17) storage.

5. Commissioning

For commissioning of unfilled batteries, see separate instructions. The level of the electrolyte must be checked. If it is below the anti-surge baffle or the top of the separator it must first be topped up to this height with purified water (DIN 43530 part 4). The charger cables must be connected to ensure a good contact, taking care that the polarity is correct. Otherwise battery, vehicle or charger could be damaged. Wipe over the tops and sides of the cells and container with a damp cloth to remove dust, water or spilt sulphuric acid. Cell cleanliness can not be too highly stressed. Check that all connections are tight.

The specified torque loading for the pole screws is 25 +/- 2Nm. (screw M10). Make sure that the cells are readily accessible for testing and topping up if the automatic watering facility is not fitted. This will make regular maintenance hassle free.

Check that the battery compartment is well drained and ventilated and that there is no risk of metal objects dropping through the top ventilation of the battery. Check that the battery sits quite firmly and securely in its housing, use suitable packing to prevent any movement when the vehicle is in motion. The cables should be flexible and of sufficient length to prevent any strain being imposed either on the cable or the certified terminals to which the cables are connected. Smear any steel runners or supports, which support the battery container with petroleum jelly. This will keep down the possibility of rust and acid corrosion and extend the life of these components.

If a new EEx battery is to be used in an application where there is uncertainty about the zoned area please contact your local factory inspector.

The battery is then charged as in item (8). The electrolyte should be topped up to the specified level with purified water(item (6)).

6. Recommended maintenance

1. Every day:

Recharge the battery after discharge.

- **Remember** never charge an EEx battery in a zoned area even if approved charging equipment is available. Always check that the charger is operating correctly.
- Check the electrolyte levels at the end of charge and top up if necessary (respect max level). The correct level is to the top of the level indicator.

FMP energy plus

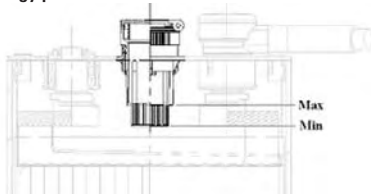

FMP LM200

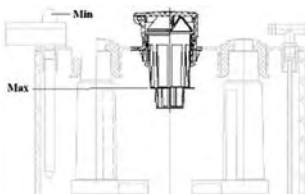

If too much water is added, the expansion during recharge will cause the electrolyte to overflow, therefore weakening the strength of the electrolyte. If insufficient water is added the top of the plates will be come exposed, reducing the performance and life of the battery.

Use approved distilled or demineralised water only.

The 'Standard' of purity of water required for topping up is given in DIN 43530 Part 4.

Suppliers of topping up water, topping up devices or automatic water filling systems can be obtained from your local supplier or service depot. Note that topping up water must only be held in and dispensed from non-metallic containers.

Never top up with acid. Should it be felt that an acid adjustment is required, please consult your local service depot.

2. Weekly:

- 2.1. • Please note any cells that are taking too much or too little water, if this occurs please contact your local service depot.
- 2.2. • Check all connections and take off leads for any frayed or worn insulation. If frayed wires or worn insulation is noted take the battery **out of service immediately** and place in a safe area that is outside the zoned area. **Do not attempt to repair a EEx battery.** Call your local service depot.
- 2.3. • Check that all insulators and vent plugs are in place and that the battery plugs are of sound condition.

Ensure that the top of the battery is clean and dry, Dirt and moisture can provide tracking paths for the electricity and potentially cause a spark in a zoned area. Should there be any corrosion of the metal container, scrape this off and neutralise the area with a solution of water and baking soda, or diluted ammonia, and protect the part from further corrosion by painting it with acid proof paint.

3. Monthly:

At the end of the charge the voltages of all cells or bloc batteries should be measured with the charger switched on, and recorded. After charging has ended the specific gravity and the temperature of the electrolyte in all cells should be measured and recorded. If significant changes from earlier measurements or differences between the cells or bloc batteries are found further testing and maintenance by the service department should be requested.

4. Annually

In accordance with EN 1175-1 at least once per year, the insulation resistance of the truck and the battery must be checked by an electrical specialist. The tests on the insulation resistance of the battery must be conducted in accordance with EN 1987 part1. The insulation resistance of the battery thus determined must not be below a value of 50 Ω per Volt of nominal voltage, in compliance with EN 50272-3. For batteries up to 20 V nominal voltage the minimum value is 1000 Ω .

Proceed to the maintenance, including the measurement of electrolyte S.G. at the end of charge. The filter of the air pump has to be checked during the annual maintenance and eventually to be cleaned or replaced. Earlier replacement of the filter is necessary if, for undefined reasons (no leaks in the air pipes) the defect signal of the air mixing system on the charger or on the battery (on DC air pump or remote signal) is illuminated. During the annual maintenance, check the correct operation of the air pump.

7. Discharge

Be sure that all breather holes are not sealed or covered. Electrical connections (e.g. plugs) must only be made or broken in the open circuit condition. To achieve the optimum life for the battery, operating discharges of more than 80% of the rated capacity should be avoided (deep discharge). This corresponds to an electrolyte specific gravity of 1.14 kg/l at 30°C at the end of the discharge for FMP energy plus batteries and 1.15 kg/l for FMP energy LM200 batteries. Discharged batteries must be recharged immediately and must not be left discharged. This also applies to partially discharged batteries.

It is recommended that the battery is discharged evenly and the use of tappings across a part of the battery is discouraged. To overcome this problem a D.C.- D.C. converter must be used to allow auxiliary loads to be supplied from the whole battery. **Note: The D.C.-D.C. converter must be certified for use in a zoned area as well as the auxiliary equipment.**

Battery performance is directly related to temperature. Batteries are rated at 30°C. Where the battery temperature is lower than this, the available performance is reduced. Additional capacity is therefore required when the batteries are to be used in areas of low ambient temperatures (e.g. cold stores).

Discharged batteries must be recharged immediately and must not be left discharged. This also applies to partially discharged batteries.

8. Recharge

Note: Never recharge a EEx battery in a zoned area.

Only direct current must be used for charging. For the FMP wf200plus range only the charge characteristics stipulated by the manufacturer are suitable for recharging; for that reason, only the chargers homologated by FMP can be used. For the FMP energy plus batteries, all charging procedures in accordance with DIN 41773-1 and DIN 41774 are permitted. Only connect the battery assigned to a charger, suitable for the size of battery, in order to avoid overloading of the electric cables and contacts, unacceptable gassing and the escape of electrolyte from the cells. In the gassing stage the current limits given in EN 50272-3 must not be exceeded. If the charger was not purchased together with the battery it is best to have its suitability checked by the manufacturers service department. When charging, proper provision must be made for venting of the charging gases. PzW batteries (wf200plus) are low gas emission, so some charging gasses are evolved. Battery container lids and the covers of battery compartments must be opened or removed.

During the charge the battery must be removed from the closed battery compartment on the truck. The ventilation must comply to EN 50272-3 standard. The vent plugs should stay on the cells and remain closed. With the charger switched off connect up the battery, ensuring that the polarity is correct. (positive to positive, negative to negative). Now switch on the charger. When charging the temperature of the electrolyte rises by about 10°C, so charging should only begin if the electrolyte temperature is below 43°C. The electrolyte temperature of batteries should be at least +10°C before charging otherwise a full charge will not be achieved. The charge is considered as finished when the specific gravity of the electrolyte and the battery voltage have remained constant for two hours.

FMP energy LM200, energy plus with air mixing ranges: If the warning light on the pump controller is illuminated or if a defect signal on the electrolyte mixing system appears, check that the piping system is connected and examine the piping circuit for leaks or defects. (see 6. Maintenance) The air pipe should never be removed during charge.

Excessive charging reduces battery life, increases water loss from the battery and wastes electricity. It is important to ensure that charger gassing times are not extended without prior consultation from your supplier.

The length of the D.C. cable between the charger and battery affects the voltage drop back to the control unit of the charger. The cable should not be extended without prior consultation with the charger manufacturer and supplier of your EEx battery.

In situations where the battery is generally only very lightly discharged, it may be an option to recharge the battery at less frequent intervals, perhaps every second day. In such circumstances please seek the advice or your local service engineer.

Do not disconnect battery until the charger has been switched off.

Your local area service centre must approve any managing charging system otherwise the warranty may be invalidated.

Equalizing

Some chargers have an equalising facility; either a manual operation or an automatic control.

For full operational procedures for the charger see manufactures instruction. **But remember never charge an EEx battery in a zoned area at any time.**

Equalising charges are used to safeguard the life of the battery and to maintain its capacity. They are necessary after deep discharges, repeated incomplete recharges and charges to an IU characteristic curve. Equalising charges are carried out following normal charging. The charging current must not exceed 5 A/100 Ah of rated capacity (end of charge).

Watch the temperature!

9. Measurement of specific gravity

To take a hydrometer reading the bulb is squeezed, the end of the rubber tube is dipped into the electrolyte and the bulb is gently released so as to draw up sufficient liquid so that the float moves freely. The hydrometer must be held in a vertical position and there should be no pressure on the rubber bulb. When reading the hydrometer to measure the specific gravity, the liquid level shows the value on the scale, which is printed on the float. After reading, the rubber bulb should be squeezed to return the electrolyte to the cell.

The rated specific gravity (S. G.) of the electrolyte is related to a temperature of 30°C and the nominal electrolyte level in the cell in fully charged condition. Higher temperatures reduce the specified gravity of the electrolyte, lower temperatures increase it. The temperature correction factor is -0.0007 kg/l per °C, e.g. an electrolyte specific gravity of 1.28 kg/l at 45°C corresponds to an S.G. of 1.29 kg/l at 30°C. The electrolyte must conform to the purity regulations in DIN 43530 part 2.

10. Temperature

An electrolyte temperature of 30°C is specified as the rated temperature. Higher temperatures shorten the life of the battery, lower temperatures reduce the capacity available. 55°C is the upper temperature limit and is not acceptable as an operating temperature.

The temperature on surface must never exceed 85°C in explosive area. Charging should only begin if the electrolyte temperature is below 43°C. If electrolyte temperature reaches 55°C during the charge, wait for the cooling before to use the battery in the explosive area. If a hot battery is detected it should be taken out of the controlled zoned area

and allowed to cool to ambient temperature. An investigation should be carried out into why the battery is getting hot before it is placed back into service. Possible reasons why the battery might be getting hot is that there might be a fault in the equipment that the battery is powering or a fault could have occurred within the cells of the battery. In the case of a suspected battery problem contact your local service centre.

11. Surrounding area conditions

The apparatus is designed to cope with the intended surrounding area conditions.

12. Effect of explosive atmosphere on materials

The materials selected are not known to react with any explosive atmospheres to which the apparatus may be subjected.

13. Protection against other hazards

The apparatus does not cause injury or harm when used as specified in the installation and operation manual.

14. Hazards arising from different ignition sources

The apparatus does not produce ignition capable electrical sparks or arcs. The apparatus has also been designed not to produce potential ignition sources from electromagnetic, acoustic, optical or other such external energy sources.

15. Withstanding attack by aggressive substances

The individual cells contains sulphuric acid: These cells and enclosure which make up the apparatus are constructed from materials that are resistant to acid attack see manufactures data sheet.

16. Care of the battery

The battery should always be kept clean and dry to prevent tracking currents. Any liquid in the battery tray must be extracted and disposed of in the prescribed manner. Damage to the insulation of the tray should be repaired after

cleaning, to ensure that the insulation value complies with EN 50272-3 and to prevent tray corrosion. If it is necessary to remove cells it is best to call in our service department for this.

17. Storage

If batteries are taken out of service for a lengthy period they should be stored in the fully charged condition in a dry, frost-free room. To ensure the battery is always ready for use a choice of charging methods can be made:

1. a monthly equalising charge as in point 8, or
2. float charging at a charging voltage of $2.27 V \times$ the number of cells.

For energy LM200 batteries:

1. After a maximum of 6 weeks storage, proceed to a full charge (see 8).
2. If the battery is equipped with measurement or control devices, a full charge is necessary after 14 days rest. The storage time should be taken into account when considering the life of the battery.

18. Malfunctions

If malfunctions are found on the battery or the charger our service department should be called in without delay. The measurements taken in point III (6) will facilitate fault finding and their elimination. A service contract with us will make it easier to detect and correct faults in good time.

Aqualevel water refilling system (optional accessory)

1. Application

The water refilling system is used to automatically maintain the nominal electrolyte levels. The charging gasses escape through the vent on each cell.

2. Function

A valve and a float together control the topping up process and maintain the correct water level in each cell. The valve allows the flow of water into each cell and the float closes the valve when the correct water level has been reached. For fault-free operation of the water refilling system, please note the instructions below:

2.1. Manual or automatic connection

The battery should be topped up shortly before completion of a full charge, as at this point the battery has reached a defined operational state resulting in satisfactory electrolyte mixing. Filling takes place when the connector (7) from the tank is connected to the coupling (6) on the battery.

- 2.1.1 If manual connection is used the battery should only be connected to the filling system once a week.
- 2.1.2 If automatic coupling is used (with a magnetic valve controlled by the charging apparatus) the charger main switch selects the correct moment for filling.
Note: In this case we recommend a water refilling at least once a week to ensure the right level of the electrolyte.

- 2.1.3 In multiple shift and warm ambient temperature operations, it may be necessary to have shorter topping up intervals.

2.2. Filling time

Filling time depends on the utilisation rate and the corresponding battery temperature. Generally speaking, the top up process takes a few minutes and can vary according to the battery range; after this, if manual filling is being used, the water supply to the battery should be turned off.

2.3. Working pressure

The water refilling system should be installed in such a way that a water pressure of 0.2 to 0.6 bar is obtained (with at least 2 m height difference between the upper edge of the battery and the lower edge of the tank). Any deviation from this means that the system will not function properly.

2.4. Purity

The topping up water must be purified. The water used to refill the batteries must have a conductance of not more than $30 \mu S/cm$. The tank and pipes must be cleaned before operating the system.

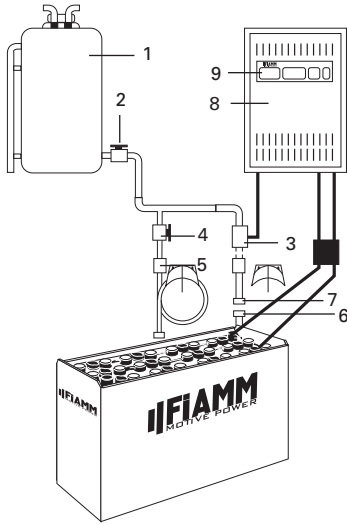

2.5. Pipe system on the battery

The pipe system to the individual battery cells must follow the battery's electrical circuit. This reduces the risk of current leakage in the presence of electrolytic gas causing an explosion (EN 50272-3). A maximum of 18 cells may be connected in a series. The system should not be modified in any way.

1. tank
2. outflow connector with ball valve
3. plug with magnetic valve
4. plug with ball valve
5. flow control
6. coupling
7. connector
8. battery charger
9. charger main switch

2.6. Working temperature

In winter, batteries fitted with Aqualevel should only be charged or refilled in a room temperature above 0 °C.

2.7. Flow control

A flow indicator built into the water supply pipe to the battery monitors the filling process. During filling the water flow causes the built-in disc in the flow indicator to turn. When all the plugs are closed the disc stops, indicating that the filling process is complete.

FMP Electrolyte circulation system (optional accessory)

1. Application

The electrolyte circulation system is based on the principle of pumping air into the individual battery cells. This system prevents electrolyte stratification and the battery charge is optimised using a charge factor of 1.07. The electrolyte circulation is particularly beneficial for heavy duty use, short charge times, boost or opportunity charging and in high ambient temperatures.

2. Function

The FMP electrolyte circulation consists of a pipe system fitted in the cells. A FMP Aeromatic diaphragm pump is fitted in the charger or separately mounted on the battery or vehicle. This diaphragm pump sends a low rate airflow into each cell which creates a circulating air stream inside the cell box. The air stream is continuous or pulsed depending on the battery voltage and pump type. The air supply is adjusted in accordance to the number of cells in the battery. The pipe system to the individual battery cells must follow the existing electrical circuit. This reduces the risk of current leakage in the presence of electrolytic gas causing an explosion (EN 50272-3).

3. Maintenance of air filter

Depending on the working conditions, the pump air filter should be changed at least once a year. In work areas with high levels of air-pollution, the filter should be checked and replaced more frequently.

4. Repair and maintenance

The system must be checked for leakage. The FMP charger will display an error message to indicate leakage. Sometimes in the case of leakage the characteristic charging curve is switched over to the characteristic standard curve (without electrolyte mixing).

In case of faulty parts, contact FMP service. Only FMP original spare parts may be used, as these are designed for the pump air supply and will ensure correct functioning of the pump.

Disposal and back to the manufacturer!

Always dispose of the battery container and cells through your local service depot. Do not attempt to dismantle the battery or the cells in any way. Once the product has failed and is no longer repairable store outside the Zoned area until removed for reclaim.

Batteries with this sign must be recycled.

Batteries which are not returned for the recycling process must be disposed of as hazardous waste!

When using motive power batteries and chargers, the operator must comply with the current standards, laws, rules, and regulations in force in the country of use!



European Headquarters:

EnerSys EMEA

EH Europe GmbH

Löwenstrasse 32

8001 Zürich

Switzerland

Phone: +41 44 215 74 10

Fax: +41 44 215 74 11

www.enersys-emea.com